

Product Summary

Part #	V _{DS}	R _{DS(on).typ}	I _D
DP072N12BGNI	120V	6.7mΩ	100A
DP072N12PGNI			

Features

- Uses advanced MOSFET-DPMOS2 technology
- Extremely low R_{DS(on)}/High Speed Power Switching
- Excellent Q_gxR_{DS(on)} product(FOM)
- Qualified according to JEDEC criteria (Industrial grade)

Applications

- Motor control and drive
- Power Management Switches
- High-frequency switching and synchronous rectification

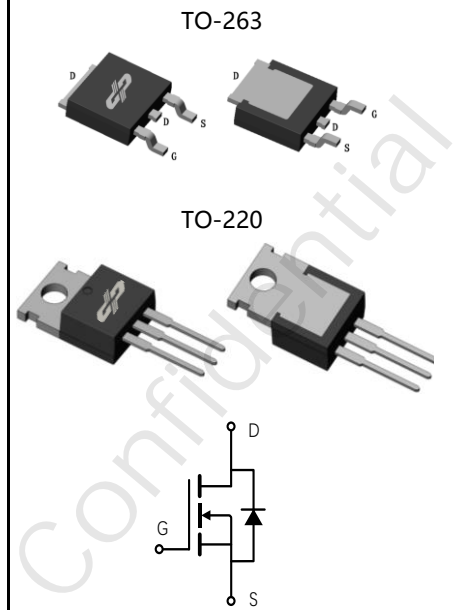

100% Avalanche Tested

 100% R_g Tested

Package Marking and Ordering Information

Part #	Marking	Package	Packing
DP072N12BGNI	072N12BGNI	TO-263	Tape/Reel
DP072N12PGNI	072N12PGNI	TO-220	Tube

Absolute Maximum Ratings

Parameter	Symbol	Value	Unit
Drain-source voltage	V _{DS}	120	V
Continuous drain current T _C = 25°C T _C = 100°C	I _D	100 64	A
Pulsed drain current (T _C = 25°C, t _p limited by T _{jmax})	I _{D pulse}	320	A
Avalanche energy, single pulse (L=0.5mH, R _g =25) ^[1]	E _{AS}	1225	mJ
Gate-Source voltage	V _{GS}	±20	V
Power dissipation (T _C = 25°C)	P _{tot}	160	W
Operating junction and storage temperature	T _j , T _{stg}	-55...+150	°C

 [1].EAS is tested at starting T_j = 25°C, V_{GS} = 10V.

Thermal Resistance

Parameter	Symbol	Max	Unit
Thermal resistance, junction – case.	R_{thJC}	0.8	°C/W
Thermal resistance, junction – ambient(min. footprint)	R_{thJA}	55	

Electrical Characteristic (at $T_j = 25\text{ }^\circ\text{C}$, unless otherwise specified)

Parameter	Symbol	Value			Unit	Test Condition
		min.	typ.	max.		
Drain-source breakdown voltage	BV_{DSS}	120	-	-	V	$V_{GS}=0V, I_D=250\mu A$
Gate threshold voltage	$V_{GS(th)}$	2.4	-	3.6	V	$V_{DS}=V_{GS}, I_D=250\mu A$
Zero gate voltage drain current	I_{DSS}	-	-	1 100	μA	$V_{DS}=120V, V_{GS}=0V$ $T_j=25^\circ C$ $T_j=150^\circ C$
Gate-source leakage current	I_{GSS}	-	-	± 100	nA	$V_{GS}=\pm 20V, V_{DS}=0V$
Drain-source on-state resistance	$R_{DS(on)}$	-	6.7 7.3	8.0 9.1	mΩ	$T_j=25^\circ C$ $V_{GS}=10V, I_D=60A$ $V_{GS}=8V, I_D=48A$
Gate resistance	R_g	-	0.6	3	Ω	$V_{GS}=0V, V_{DS}=0V,$ $f=1MHz$
Transconductance ^[2]	g_{fs}	-	145	-	S	$V_{DS}=5V, I_D=40A$

Dynamic Characteristic^[2]

Input Capacitance	C_{iss}	-	3511	-	pF	$V_{GS}=0V, V_{DS}=60V,$ $f=1MHz$
Output Capacitance	C_{oss}	-	432	-		
Reverse Transfer Capacitance	C_{rss}	-	17	-		
Gate Total Charge@ $V_{GS}=10V$	Q_g	-	48	-	nC	$V_{GS}=10V, V_{DS}=60V,$ $I_D=20A, f=1MHz$
Gate-Source charge	Q_{gs}	-	18	-		
Gate-Drain charge	Q_{gd}	-	10	-		
Turn-on delay time	$t_{d(on)}$	-	10	-	ns	$V_{GS}=10V, V_{DD}=60V,$ $R_{G_ext}=2.7\Omega, I_D=20A$
Rise time	t_r	-	24	-		
Turn-off delay time	$t_{d(off)}$	-	31	-		
Fall time	t_f	-	17	-		

Body Diode Characteristic

Parameter	Symbol	Value			Unit	Test Condition
		min.	typ.	max.		
Body Diode Forward Voltage	V_{SD}	-	0.85	1.2	V	$V_{GS}=0V, I_{SD}=40A$
Diode continuous forward current	I_S	-	-	80	A	$T_C = 25^\circ C$
Diode pluse current	$I_{S\ pluse}$	-	-	320	A	$T_C = 25^\circ C$
Body Diode Reverse Recovery Time ^[2]	t_{rr}	-	44	-	ns	$I_F=20A, di/dt=100A/\mu s$
Body Diode Reverse Recovery Charge ^[2]	Q_{rr}	-	72	-	nC	

[2]. Defined by design. Not subject to production test

Typical Performance Characteristics

Fig 1: Output Characteristics

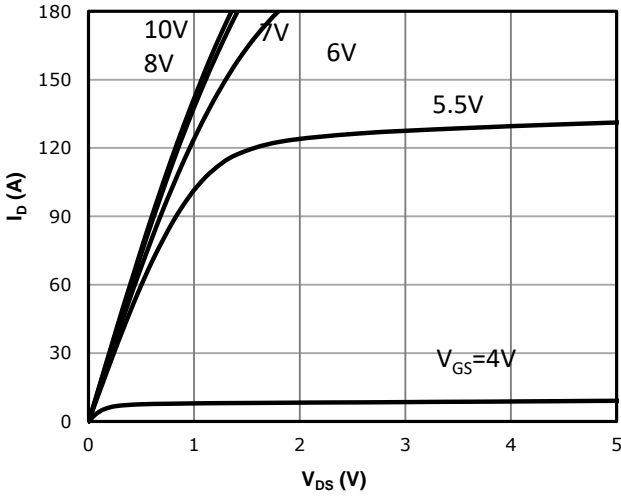

Fig 2: Transfer Characteristics

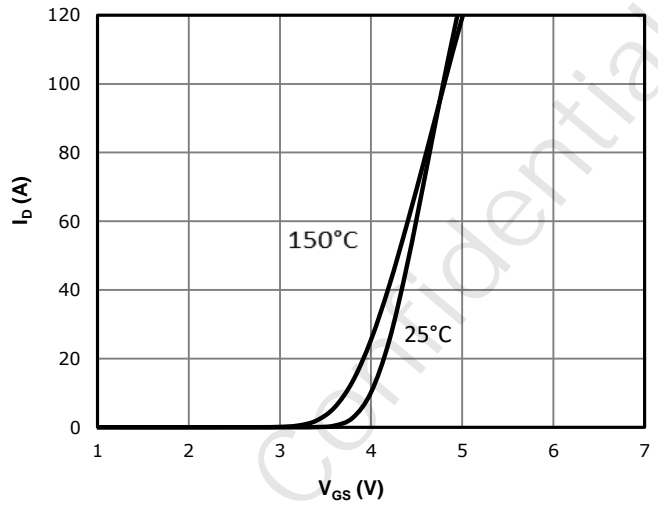

Fig 3: $R_{DS(on)}$ vs Drain Current and Gate Voltage

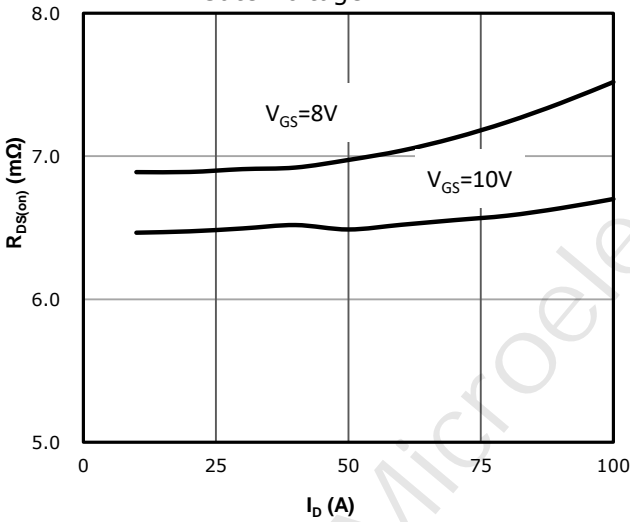

Fig 4: $R_{DS(on)}$ vs Gate Voltage

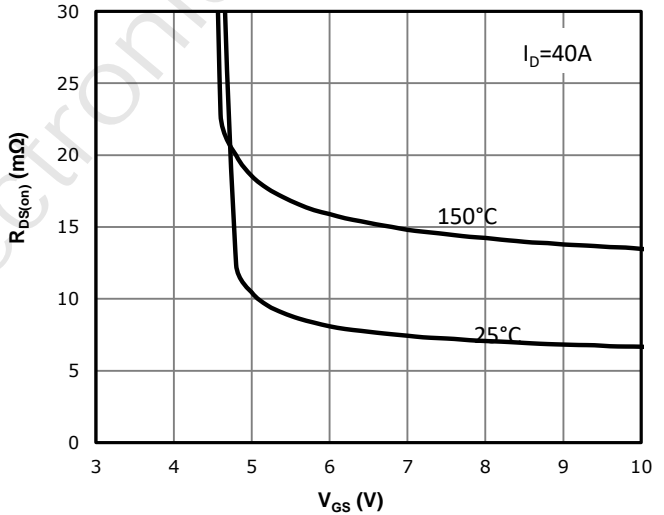

Fig 5: $R_{DS(on)}$ vs. Temperature

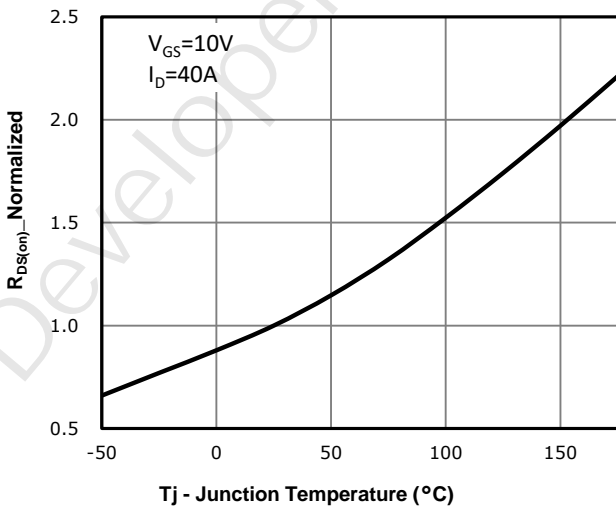

Fig 6: Capacitance Characteristics

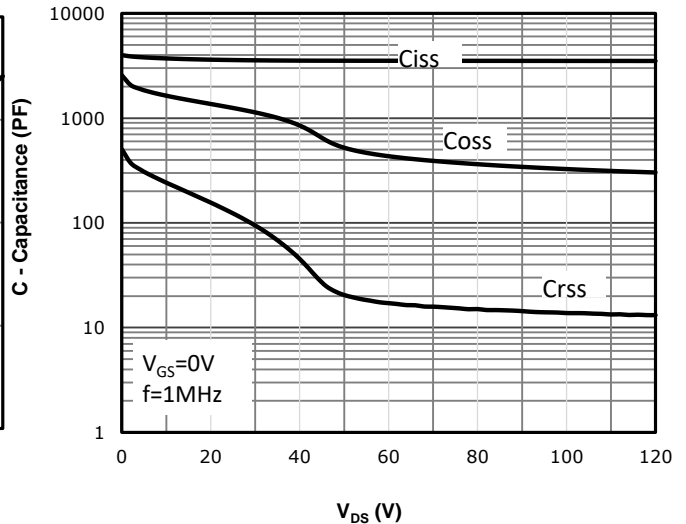

Fig 7: Gate Charge Characteristics

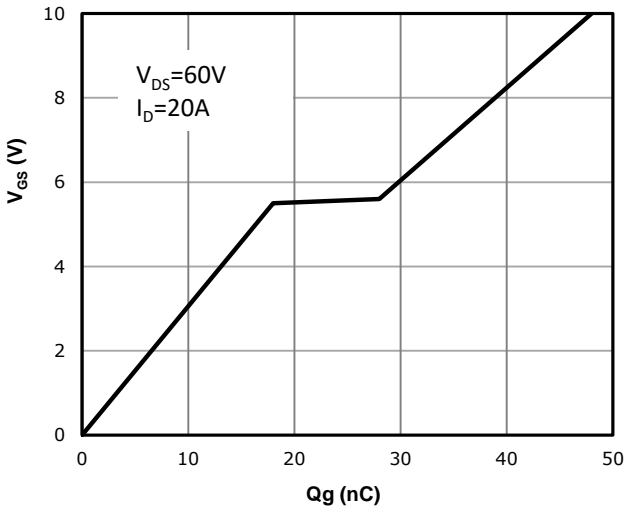

Fig 8: Body-diode Forward Characteristics

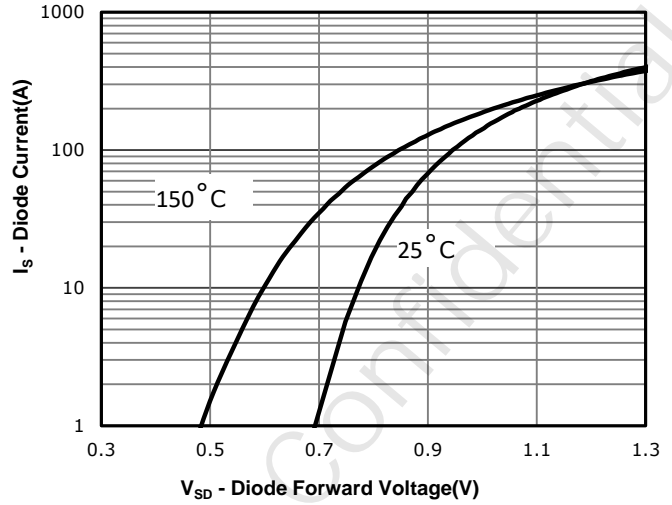

Fig 9: Power Dissipation

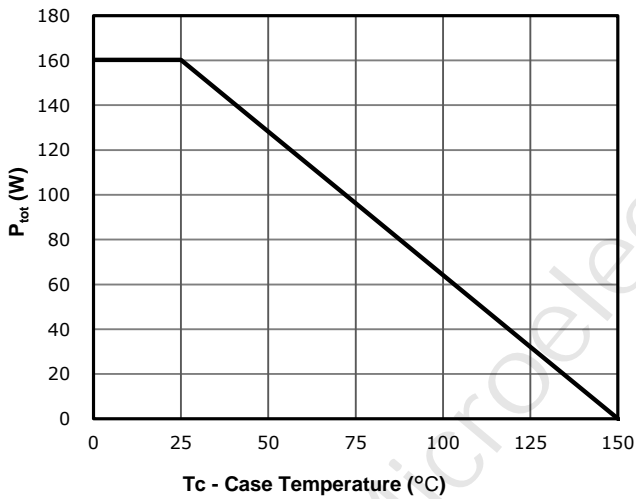

Fig 10: Drain Current Derating

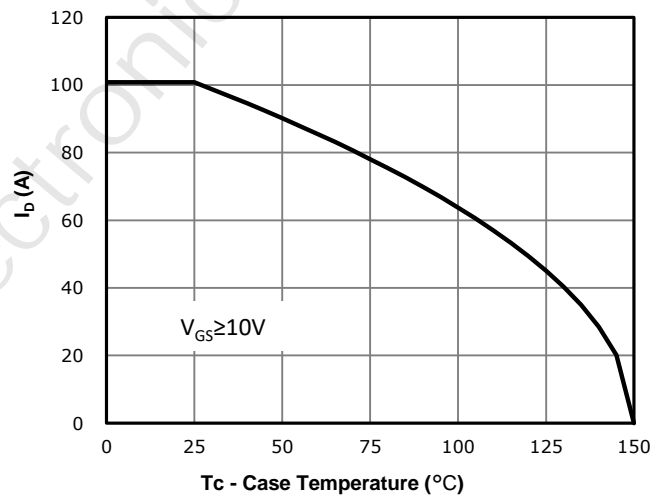

Fig 11: Safe Operating Area

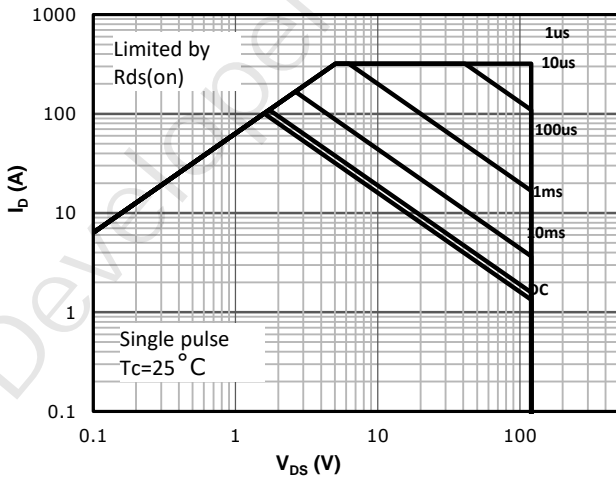
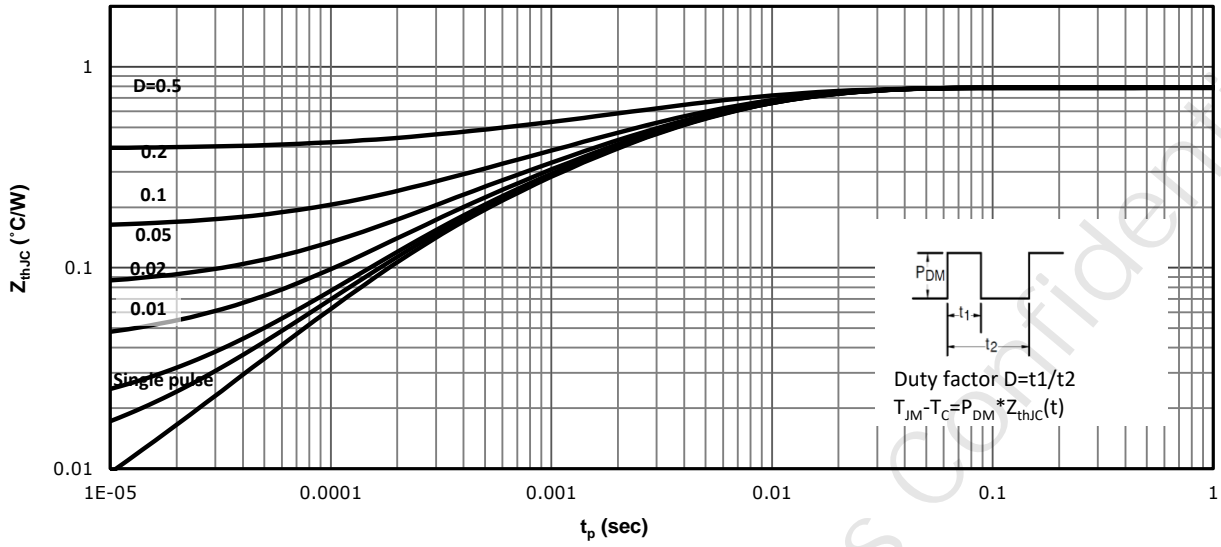
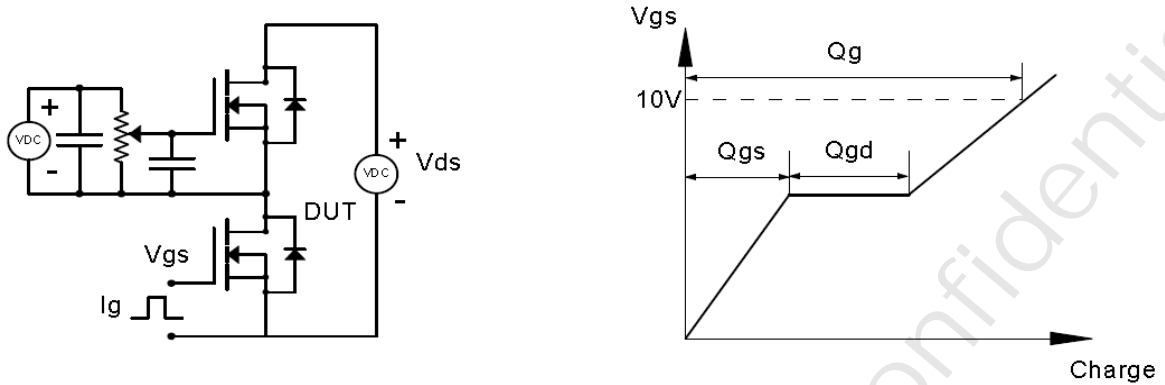

Fig 12: Max. Transient Thermal Impedance



Test Circuit & Waveform

Gate Charge Test Circuit & Waveform



Resistive Switching Test Circuit & Waveforms

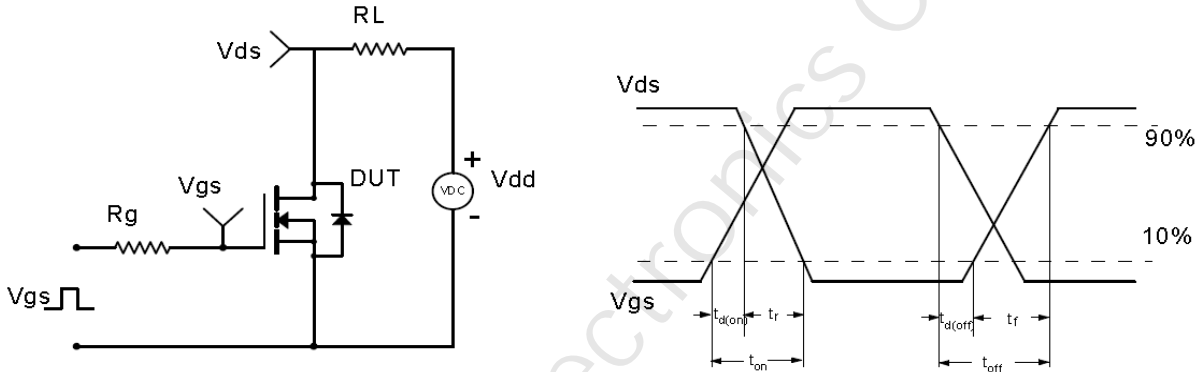

Unclamped Inductive Switching (UIS) Test Circuit & Waveforms

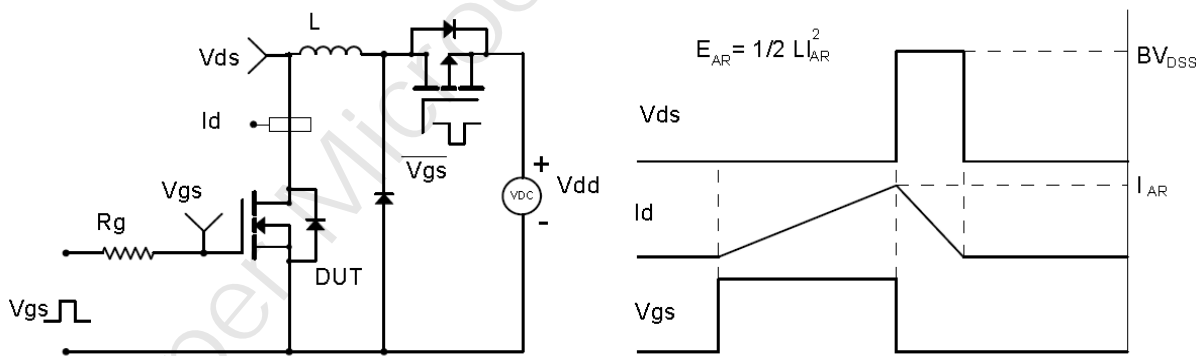

Diode Recovery Test Circuit & Waveforms

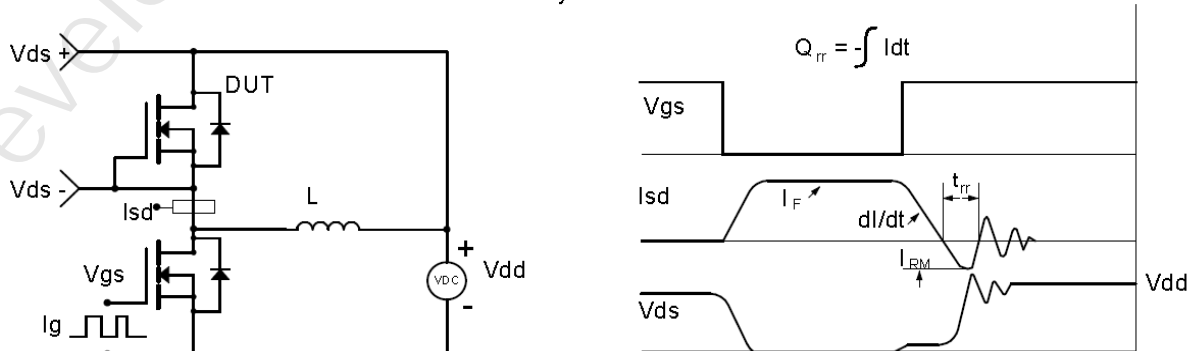

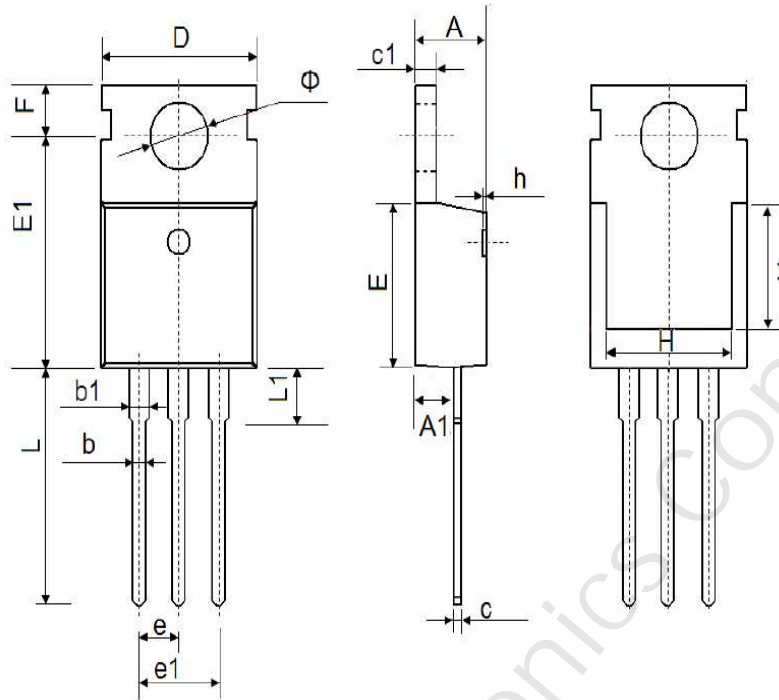
Package Outline: TO-220-3L

Symbol	Dimensions In Millimeters		Dimensions In Inches	
	Min.	Max.	Min.	Max.
A	4.30	4.70	0.169	0.185
A1	2.25	2.55	0.089	0.100
b	0.71	0.91	0.028	0.036
b1	1.17	1.37	0.046	0.054
c	0.33	0.65	0.013	0.026
c1	1.20	1.40	0.047	0.055
D	9.91	10.25	0.390	0.404
E	8.95	9.75	0.352	0.384
E1	12.65	12.95	0.498	0.510
e	2.54 BSC.		0.100 BSC.	
e1	4.98	5.18	0.196	0.204
F	2.65	2.95	0.104	0.116
H	7.90	8.10	0.311	0.319
h	0.00	0.30	0.000	0.012
L	12.90	13.40	0.508	0.528
L1	2.85	3.25	0.112	0.128
V	7.500 Ref.		0.295 Ref.	
Φ	3.400	3.800	0.134	0.150

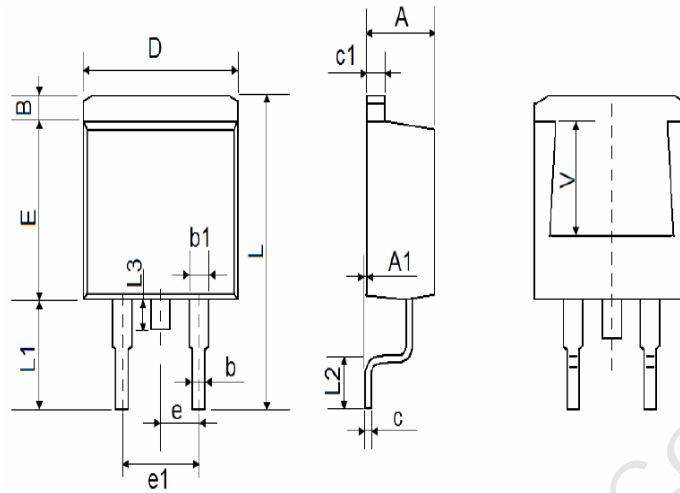
Package Outline: TO-263

Symbol	Dimensions In Millimeters		Dimensions In Inches	
	Min.	Max.	Min.	Max.
A	4.40	4.80	0.173	0.189
A1	0.00	0.15	0.000	0.006
B	1.17	1.37	0.046	0.054
b	0.71	0.91	0.028	0.036
b1	1.17	1.37	0.046	0.054
c	0.31	0.53	0.012	0.021
c1	1.17	1.37	0.046	0.054
D	10.01	10.31	0.394	0.406
E	8.50	8.90	0.335	0.350
e	2.54 BSC.		0.100 BSC.	
e1	4.98	5.18	0.196	0.204
L	15.05	15.45	0.593	0.608
L1	5.08	5.48	0.200	0.216
L2	2.34	2.74	0.092	0.108
L3	1.30	1.70	0.051	0.067
V	5.600 Ref.		0.220 Ref.	

Part Marking Information

Absolute Maximum Ratings

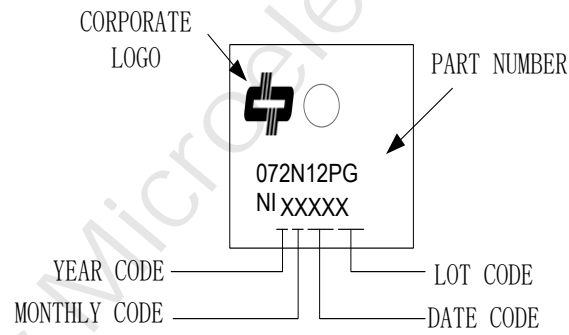
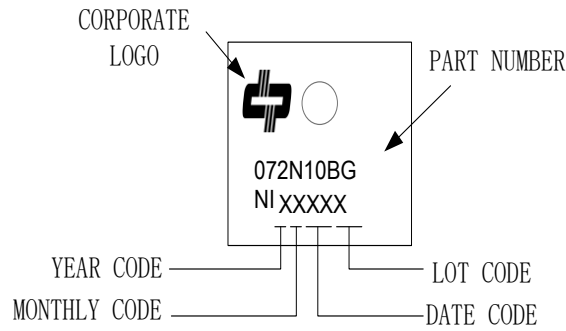

Revision History

Revision	Major changes
1.0	Release for formal version

重要声明 Important Notice

德普微尽力确保本产品规格书内容的准确和可靠，但是保留在没有通知的情况下，修改规格书内容的权利。客户在下订单前应联系德普微获取最新的相关信息，并验证这些信息是否完整且是最新的。所有产品的销售都遵循在订单确认时所提供的本公司销售条款与条件。

德普微会不定期更新本文档内容，产品实际参数可能因型号或者其他事项不同有所差异，本文档不作为任何明示或暗示的担保或授权。

本产品规格书未包含任何针对德普微或第三方所有的知识产权的授权。针对本产品规格书所记载的信息，德普微不做任何明示或暗示的保证，包括但不限于对规格书内容的准确性、商业上的适销性，特定目的的适用性或者不侵犯德普微或任何第三人知识产权做任何明示或暗示保证，德普微也不就因本规格书本身及其使用有关的偶然或必然损失承担任何责任。

德普微对应用帮助或客户产品设计不承担任何义务。客户应对其使用本公司的产品和应用自行负责。为尽量减小与客户产品和应用相关的风险，客户应提供充分的设计与操作安全验证。

针对本规格书所披露的内容，在未获得德普微的授权下，任何第三方不得使用、复制、转换，一经发现本公司必依法追究其法律责任，并赔偿由此对本公司造成的一切损失。

请注意在本资料记载的条件范围内使用产品，特别请注意绝对最大额定值、工作电压范围和电气特性等。因在本资料记载的条件范围外使用产品而造成的故障和(或)事故等的损害，本公司对此概不承担任何责任。

本公司一直致力于提高产品的质量和可靠度，但所有的半导体产品都有一定的失效概率，这些失效概率可能会导致一些人身事故、火灾事故等。当设计产品时，请充分留意冗余设计并采用安全指标，这样可以避免事故的发生。

使用本公司的IC生产产品时，如因其产品中对该IC的使用方法或产品的规格，或因进口国等原因，包含本IC产品在内的制品发生专利纠纷时，本公司概不承担相应责任。